



[Home](#)

[Products](#)

[Dealer Locator](#)

[Financing](#)

[News](#)

[Dealer Portal](#)

[About Gehl](#)

[Investor Relations](#)

# E-Series Skid Loaders

## SPECIFICATIONS

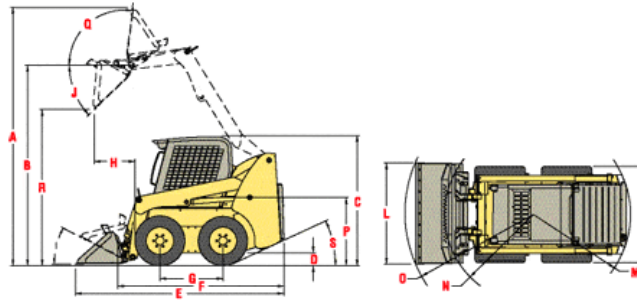

	3640E	4240E	4640E / 4640E Turbo	4840E	5640E / 5640E Turbo	6640E
<b>DIMENSIONS</b>						
<b>A. Overall Operating Height (fully raised)</b>	139.6" (3546)	141.1" (3584)	149" (3785)	149" (3785)	162" (4115)	168.3" (4274)
<b>B. Height to Hinge Pin (fully raised)</b>	108.1" (2746)	110" (2794)	115.5" (2934)	115.5" (2934)	123" (3124)	124.3" (3157)
<b>C. Overall Height (w/ ROPS/FOPS)</b>	70.3" (1786)	71.9" (1826)	78.0" (1981)	78.0" (1981)	81.0" (2057)	82.0" (2082)
<b>D. Ground Clearance</b>	6" (152)	8.3" (211)	7.5" (191)	7.5" (191)	8" (203)	9.1" (231)
<b>E. Overall Length</b>	114.0" (2896) (w/55" bucket)	116.2" (2952) (w/61" bucket)	122.8" (3119) (w/66" bucket)	126.3" (3208) (w/66" bucket)	131.0" (3327) (w/70" bucket)	141.5" (3594) (w/74" bucket)
<b>F. Overall Length (less bucket)</b>	88.9" (2258)	91.1" (2314)	89.8" (2291)	93.3" (2370)	95.5" (2426)	101.0" (2565)
<b>G. Wheelbase</b>	34.5" (876)	36.7" (932)	37.5" (953)	41.5" (1054)	42.5" (1080)	48.4" (1219)
<b>H. Dump Reach (at full height)</b>	22.8" (579)	22.6" (574)	27.6" (701)	27.6" (701)	32.8" (833)	34.3" (863)
<b>I. Rollback (at ground)</b>	29°	29°	27°	27°	30°	30°
<b>J. Dump Angle (at full height)</b>	42°	42°	40°	40°	40°	40°
<b>K. Overall Width (less bucket)</b>	48.4" (1229)	52.5"/58.4" (1334/1483)	63.5" (1613)	63.5" (1613)	67.0" (1702)	72.5" (1841)
<b>L. Overall Width (with bucket)</b>	55.3" (1404)	60.6" (1539)	66" - 72" (1679 - 1829)	66" - 75" (1679 - 1905)	70" - 90" (1778 - 2286)	74" - 90" (1880 - 2286)
<b>M. Clearance Circle (rear)</b>	54.1" (1374)	58.4" (1484)	59.5" (1513)	61.5" (1562)	66.0" (1679)	69.0" (1753)
<b>N. Clearance Circle (front, less bucket)</b>	44.1" (1120)	43.4" (1102)	47" (1194)	48" (1219)	50.5" (1283)	54.0" (1372)
<b>O. Clearance Circle (front, w/bucket)</b>	69.4" (1763)	69.2" (1758)	74.5" (1892)	76.0" (1930)	82.0" (2083)	90.5" (2299)
<b>P. Seat to Ground Height</b>	32.6" (828)	33.6" (853)	37.5" (953)	37.5" (953)	42.0" (1067)	43.3" (1100)
<b>Q. Rollback Angle (at Full Height)</b>	99°	99°	86°	86°	84°	84°
<b>R. Dump Height</b>	84.5" (2146)	86.5" (2197)	89.5" (2273)	89.5" (2273)	93.5" (2375)	94.8" (2408)

<b>S. Departure Angle</b>	26°	29°	25°	25°	26°	29°
<b>Standard Tire Size</b>	27x8.5x15 HD	10.00x16.5 HD	10.00x16.5 HD	10.00x16.5 HD	12.00x16.5 HD	14.00x17.5 HD

<b>ENGINE</b>						
<b>Make</b>	Yanmar	Yanmar	Deutz <sup>(A)</sup>	Deutz	Deutz <sup>(A)</sup>	Deutz
<b>Model</b>	3TNV88	4TNV88	F3M2011/ BF3M2011	F4M2011	F4M2011/ BF4M2011	BF4M2011
<b>Net Power (kW) @ RPM</b>	35 hp (26) @ 2600	46 hp (34) @ 2600	46/60 hp (34/45) @ 2600	60 hp (45) @ 2500	60/82 hp (45/61) @ 2500	82 hp (61) @ 2500
<b>Displacement (L)</b>	100 cu. in. (1.64)	133 cu. in. (2.19)	142 cu. in. (2.3)	190 cu. in. (3.1)	190 cu. in. (3.1)	190 cu. in. (3.1)

<b>HYDRAULIC SYSTEM</b>						
<b>T-bar Hand Controls, Hand/Foot Controls or Dual-Hand Controls<sup>(C)</sup></b>	Traction/Lift/Tilt	Traction/Lift/Tilt	Traction/Lift/Tilt	Traction/Lift/Tilt	Traction/Lift/Tilt	Traction/Lift/Tilt
<b>Auxiliary Hyd. (L/min)</b>	14.5 gpm (55)	16.5 gpm (62)	19 gpm (72)	19 gpm (72)	23 gpm (87.1)	23 gpm (87.1)
<b>High-Flow Hyd. (L/min) – opt.</b>	N/A	N/A	30 gpm (114)	30 gpm (114)	36 gpm (136.3)	36 gpm (136.3)
<b>Filtration</b>	4 micron	4 micron	3 micron	3 micron	3 micron	3 micron
<b>Reservoir Capacity (L)</b>	8 gal. (30.3)	8 gal. (30.3)	12 gal. (45)	12 gal. (45)	16 gal. (60)	16 gal. (60)

<b>ELECTRICAL SYSTEM</b>						
<b>Battery</b>	12-volt (675 CCA)	12-volt (675 CCA)	12-volt (950 CCA)	12-volt (950 CCA)	12-volt (950 CCA)	12-volt (950 CCA)
<b>Starter (kW)</b>	12-volt (2.3)	12-volt (2.3)	12-volt (2.3)	12-volt (2.3)	12-volt (2.3)	12-volt (2.3)
<b>Alternator</b>	40-amp.	40-amp.	95-amp.	95-amp.	95-amp.	95-amp.

<b>CAPACITIES / WEIGHTS</b>						
<b>Rated Operating Load<sup>(D)</sup> (kg)</b>	1050 lbs. (476)	1350 lbs. (612)	1550 lbs. (680) / 1650 lbs. (748)	1900 lbs. (862)	2050 lbs. (930) / 2200 lbs. (998)	2600 lbs. (1179)
<b>Rated Operating Load w/ Opt. Counterweight<sup>(D)</sup> (kg)</b>	1175 lbs. (533)	1475 lbs. (669)	1700 lbs. (771) / 1800 lbs. (816)	2050 lbs. (930)	2350 lbs. (1066) / 2500 lbs. (1134)	2900 lbs. (1315)
<b>Tipping Capacity<sup>(D)</sup> (kg)</b>	2100 lbs. (952)	2700 lbs. (1225)	3100 lbs. (1361) / 3300 lbs. (1497)	3800 lbs. (1724)	4100 lbs. (1860) / 4400 lbs. (1996)	5200 lbs. (2359)
<b>Fuel Tank (L)</b>	10.3 gal. (38.9)	12.4 gal. (47)	15 gal. (56)	15 gal. (56)	19 gal. (72)	24 gal. (91)
<b>Travel Speed - max. (km/h)</b>	6.8 mph (10.9)	6.4 mph (10.3)	8.1 mph (13) / 11.4 mph (18.3) <sup>(E)</sup>	8.1 mph (13) / 11.4 mph (18.3) <sup>(E)</sup>	8.4 mph (13.5) / 12.5 mph (20) <sup>(E)</sup>	8.4 mph (13.5) / 12.5 mph (20) <sup>(E)</sup>
<b>Operating Weight<sup>(F)</sup> (approx.) (kg)</b>	4000 lbs. (1814)	4600 lbs. (2087)	6200 lbs. (2812)	6480 lbs. (2939)	7380 lbs. (3347)	7800 lbs. (3538)

	3640E	4240E	4640E / 4640E Turbo	4840E	5640E / 5640E Turbo	6640E
<b>FEATURED EQUIPMENT</b>						
<b>Auxiliary Hydraulics</b>	Yes	Yes	Yes	Yes	Yes	Yes
<b>Brake Control (auto / manual)</b>	Yes	Yes	Yes	Yes	Yes	Yes
<b>Engine Heater</b>	Opt.	Opt.	Opt.	Opt.	Opt.	Opt.
<b>Foot &amp; Hand Throttles</b>	Yes <sup>(G)</sup>	Yes <sup>(G)</sup>	Yes <sup>(G)</sup>	Yes <sup>(G)</sup>	Yes <sup>(G)</sup>	Yes <sup>(G)</sup>
<b>Anti-Vandalism Protection</b>	Yes	Yes	Yes	Yes	Yes	Yes
<b>Full Instrumentation</b>	Yes	Yes	Yes	Yes	Yes	Yes
<b>T-bar Hand Controls Available</b>	Yes	Yes	Yes	Yes	Yes	Yes
<b>Hand/Foot Controls Available</b>	Yes	Yes	Yes	Yes	Yes	Yes
<b>Dual-Hand Controls Available</b>	No	No	Yes	Yes	Yes	Yes
<b>Hourmeter</b>	Yes	Yes	Yes	Yes	Yes	Yes
<b>Hydraloc™ System</b>	Yes	Yes	Yes	Yes	Yes	Yes
<b>Hydrostatic Drive</b>	Yes	Yes	Yes	Yes	Yes	Yes
<b>Independent Hydraulic Reservoir</b>	Yes	Yes	Yes	Yes	Yes	Yes
<b>Integral Access Plate (removable)</b>	Yes	Yes	Yes	Yes	Yes	Yes
<b>Lift Arm Support Device</b>	Yes	Yes	Yes	Yes	Yes	Yes
<b>Operational Lights - frt. &amp; rear</b>	Yes	Yes	Yes	Yes	Yes	Yes
<b>Operator Restraint Bar with Padded Armrests/ Seat Belt</b>	Yes	Yes	Yes	Yes	Yes	Yes
<b>Engine Auto-Shutdown System</b>	Opt.	Opt.	Yes	Yes	Yes	Yes
<b>All-Tach® Attachment Mounting</b>	Yes	Yes	Yes	Yes	Yes	Yes
<b>ROPS/FOPS Level II Overhead Guard (w/integral side screens)</b>	Yes	Yes	Yes	Yes	Yes	Yes
<b>Self-Leveling Lift Action</b>	Opt.	Opt.	Yes	Yes	Yes	Yes
<b>Sound Level Reduction Package</b>	Opt.	Opt.	Yes	Yes	Yes	Yes
<b>Spark-Arrestor Muffler</b>	Yes	Yes	Yes <sup>(H)</sup>	Yes	Yes <sup>(H)</sup>	No

A. 4640E turbo versions use Deutz BF3M2011 Turbo engine - 60 hp

B. 5640E turbo versions use Deutz BF4M2011 Turbo engine - 82 hp

C. Dual-hand controls not available on 3640E/4240E

D. Per SAE J818 and J732, and ISO 14397

E. With 2-speed drive option

F. Base unit with standard equipment, standard tires, standard bucket, and 175 lb. (79 kg) operator

G. Foot throttle is standard with T-Bar and Dual-Hand controls, but not available with Hand/Foot controls

H. Naturally aspirated engines have spark-arrestor mufflers

